

HF-450H Sleeve Labeling Machine



1. Price

Name	Model	Price(USD)	Quantity	Amount	Remark
Sleeve labeling machine	HF-400H	18000	1	18000	
Conveyor	82.5mmbelt/10cm	180	9m	1620	304 Steel bars/plastic belt
Steam shrink tunnel	HF-2800M	2,700	1	2700	
Steam boiler	36kw	2300	1	2300	with water softener
Total Amount	FOB SHANGHAI 24120\$				
Remark: 1. Payment: T/T 30% in advance, 70%TT before ex-work. 2. Shipment time :30days since get deposit and samples of bottles &labels					

3.introductions

we update the 450H model machine from 400H model, add functions/parts as below:

(1) 8 rubber rolls to feed sleeve from 6 rolls, driving belts are much different to 400H, sleeves inserting to bottles is more stable.

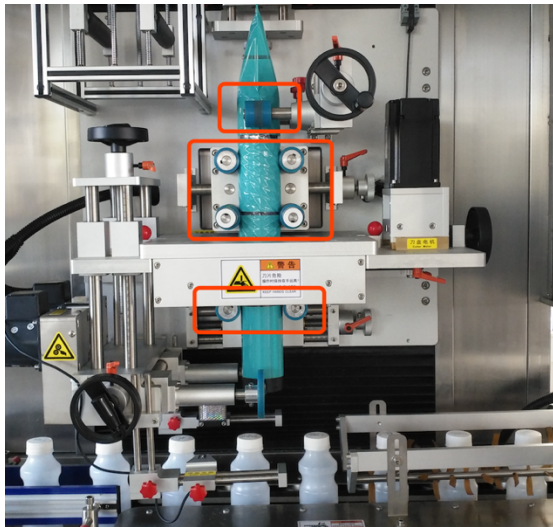

(2) New two belts system to keep running on conveyor



(3) Two reels on ground



(4) New operation panel

- (5) Machine stops when no sleeve any more.
- (6) Machine stops when bottles get traffic in conveyor
- (7) New motors for bottles separating for stopping
- (8) Machine stops when no bottles come

3. Information about the bottles & labels

100ml yogurt bottle, full body sleeves.

4. Layout for the sleeve labeling line for reference.

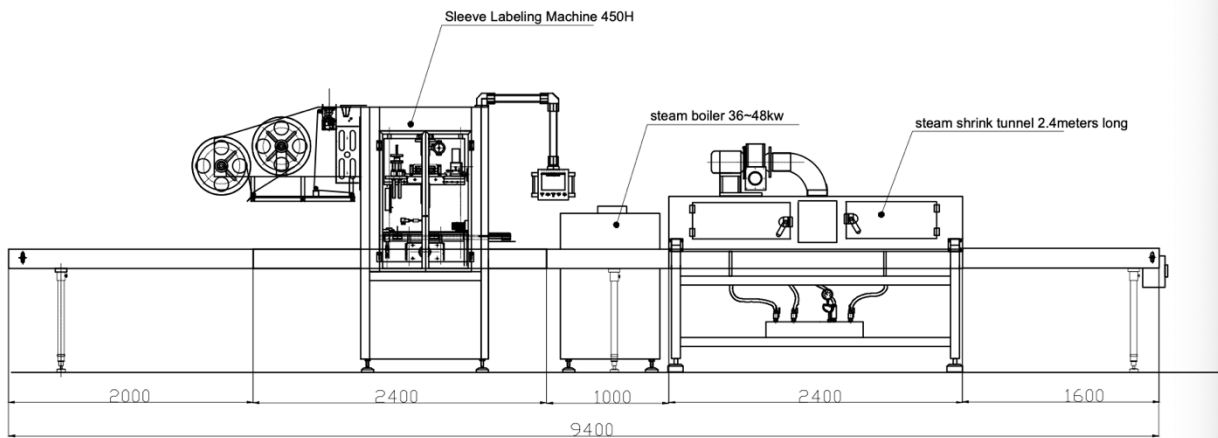

Remark:

- (1) Please confirm the direction to feed bottles from the left to right, or from the right to left is optional
- (2) The height of conveyor can be changed as request.



5. Main Parameters

Machine	Machine model	HF-450H
	Capacity	450bpm/sleeve height/ 8~10cm
	Size L*W*H	2400*850*2000mm
	Weight	700Kgs
	Powder supply	AC3-Phase 220/380V
	Eligibility percent	≥99.8%
	Total powder	3.5KW
Shrinkable labels	Materials	PVC、PET、OPS
	Thickness	0.03~0.13mm
	Labels Length/height	40~280Mm
	Flat width	Max200Mm
	Inner Dia. Of Labels roll	76mm
Bottles to pack	Height	Max320mm
	Diameter	Ø28- Ø125mm
	Material	Glass、Metal 、Plastic
	Shapes	Round, square, flat, curved cup-shaped bottles



6. Fittings List

Electric appliance cabinet			
PLC	FP-XHC40T	1	PANASONIC
Touch screen	IT5070-1	1	WEINVIEW
Power switch	MW-220-50-24	1	MIMWEI
Low-voltage electric appliance	D181025A	2	OMRON
Circuit breaker	D247-63	1	DELIXI
Fuse	10AHG30-32	4	EARLISON
Relay module	10A	4	SIEMENS
Relay socket	DTF-08A	9	PANJE
Capacitance	5UF	1	DELIXI
	7UF	1	
	1.8UF	2	
Contactor	CJ*21210	2	DELIXI
Emergency stop button	PR15	1	SCHNEIDER
Indication light	NZH145	1	NANZHOU



8. Packing box & sizes

Wooden box sizes

Models	Sleeve labeling machine	Steam tunnel	Steam generator
Packing wooden case (L×W×H) m	2.4×1.25×2.2m	2.1×0.5×1 m	0.8*0.6*1.1
Volume (m3)	7	1.2	0.53
Weight(kg) wooden box included	800kg	220kg	130kg

Faith based on the market, quality cast success!

Professional Manufacturer, Outstanding Quality and Most Reliable Prod